



**Homework Helpers**

**Grade 4**  
**Module 4**



## G4-M4-Lesson 1

1. Use the following directions to draw a figure in the box below.
  - a. Draw two points:  $J$  and  $K$ .
  - b. Use a straightedge to draw  $\overleftrightarrow{JK}$ . I read this as "line  $JK$ ."
  - c. Draw a new point that is on  $\overleftrightarrow{JK}$ . Label it  $L$ .
  - d. Draw a point not on  $\overleftrightarrow{JK}$ . Label it  $M$ .
  - e. Construct  $\overline{LM}$ . I read this as "line segment  $LM$ ."
  - f. Use the points you've already labeled to name two angles.  $\angle JLM, \angle MLK$
  - g. Identify the angles you've labeled by drawing an arc to indicate the position of the angles.

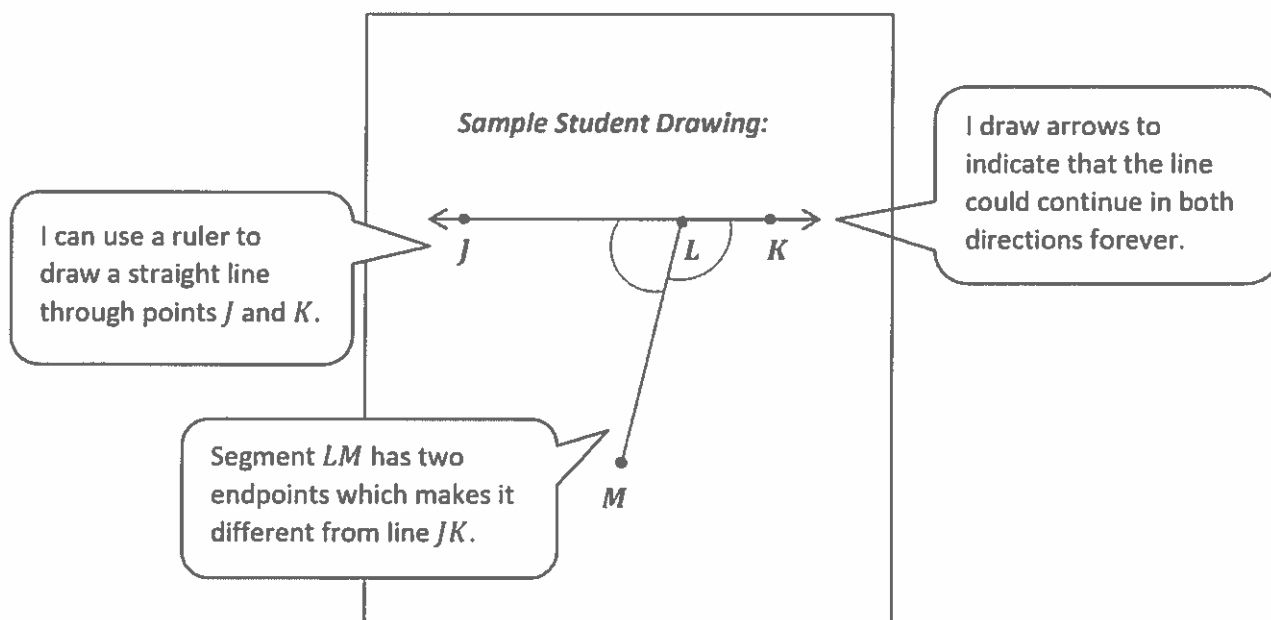

2.

- a. Observe the familiar figures below. Label some points on each figure.
- b. Use those points to label and name representations of each of the following in the table below: ray, line, line segment, and angle. Extend segments to show lines and rays.

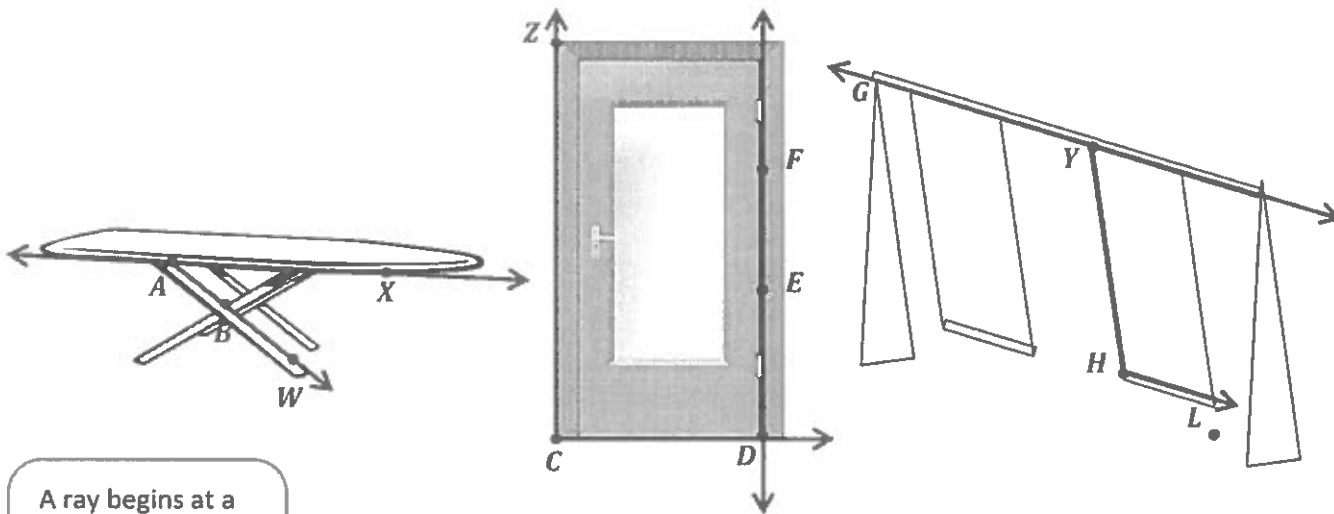

A ray begins at a point and extends indefinitely in one direction.

	Ironing Board	Door	Swing Set
Ray	$\overrightarrow{AW}$	$\overrightarrow{CD}$	$\overrightarrow{HL}$
Line	$\overleftrightarrow{AX}$	$\overleftrightarrow{DF}$	$\overleftrightarrow{GY}$
Line Segment	$\overline{AB}$	$\overline{EF}$	$\overline{YH}$
Angle	$\angle WAX$	$\angle ZCD$	$\angle YHL$

I write symbols for angle ( $\angle$ ), segment ( $\overline{\quad}$ ), ray ( $\overrightarrow{\quad}$ ), and line ( $\overleftrightarrow{\quad}$ ).

G4-M4-Lesson 2

I can remake a right angle template using a circle of paper. I fold it into fourths and use the square corner.

- Use the right angle template that you made in class to determine if each of the following angles is greater than, less than, or equal to a right angle. Label each as *greater than*, *less than*, or *equal to*, and then connect each angle to the correct label of acute, right, or obtuse.

I draw a line to "acute" because it names this angle that is less than a right angle.

a. *less than*

b. *equal to*

c. *equal to*

d. *greater than*

● Obtuse ●

● Right ●

● Acute ●

- Construct an obtuse angle using a straightedge and the right angle template that you created. Explain the characteristics of an obtuse angle by comparing it to a right angle. Use the words *greater than*, *less than*, or *equal to* in your explanation.

**Sample explanation:**

*The measure of an obtuse angle is greater than the measure of a right angle.*

I use my right angle template to plot point  $K$  so that when I draw a second ray,  $\overline{AK}$ ,  $\angle KAT$  will measure greater than a right angle.

I draw points  $A$  and  $T$ . Then, I use my straightedge to draw  $\overline{AT}$ .

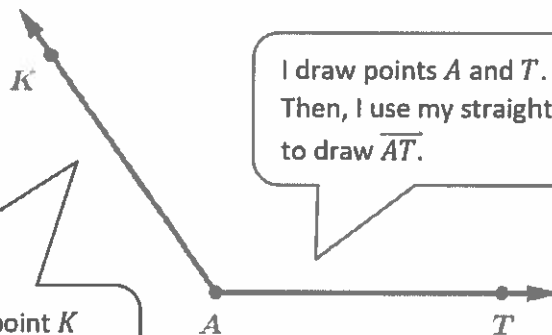

### G4-M4-Lesson 3

- On each object, trace at least one pair of lines that appear to be perpendicular.

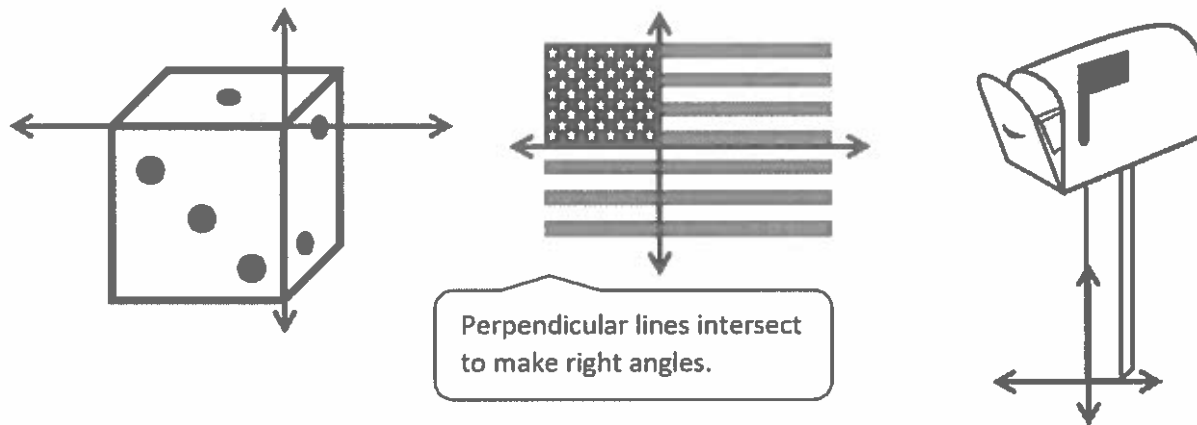

- In the grid below, draw a segment that is perpendicular to the given segment. Use a straightedge.

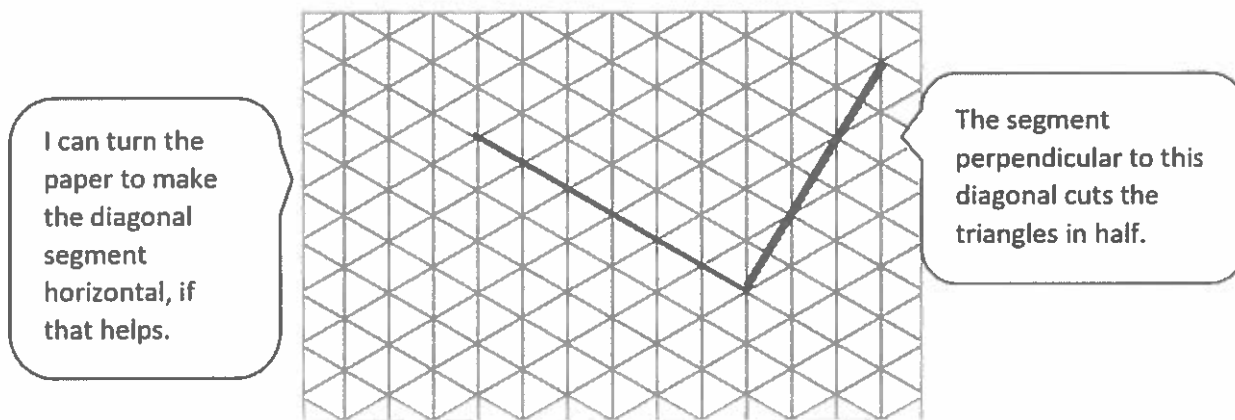

3. Use the right angle template that you created in class to determine if the following figure has a right angle. If so, mark it with a small square. For each right angle you find, name the corresponding perpendicular sides.

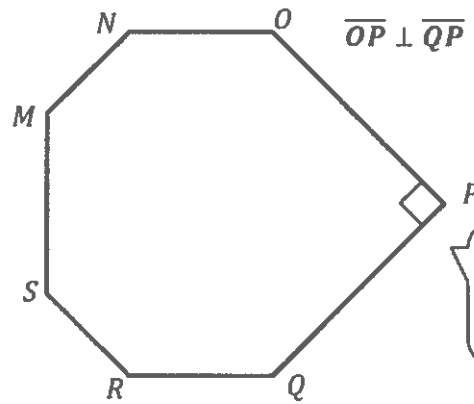

I use a symbol to note the sides are perpendicular.

I align the template with each angle. Angle  $P$  matches perfectly!

## G4-M4-Lesson 4

1. On each object, trace at least one pair of lines that appear to be parallel.

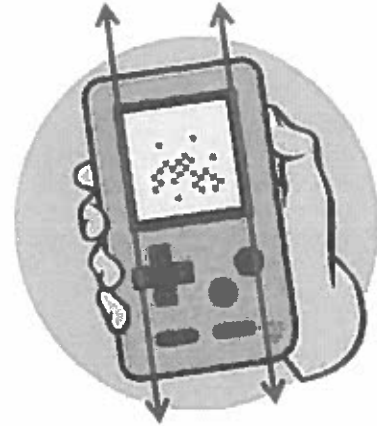
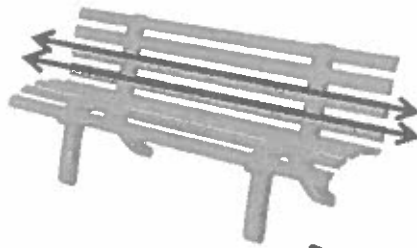
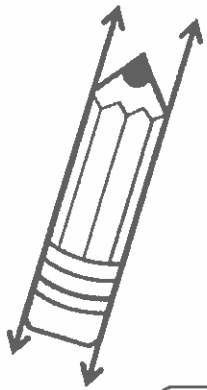

Parallel lines never touch no matter how far you extend them.

2. In the grid below, use a straightedge to draw a segment that is parallel to the given segment.

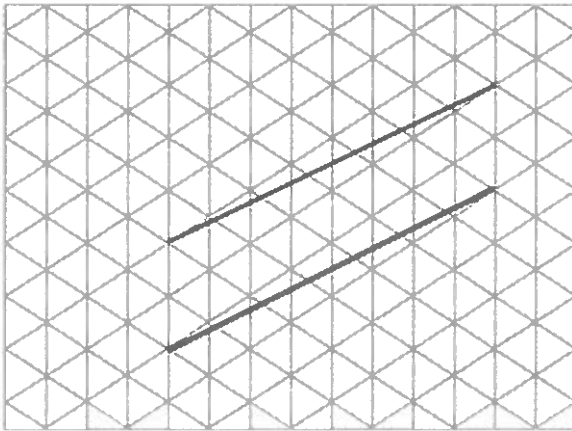

It's tricky to draw diagonal parallel line segments! I draw a line segment that is a distance of two triangle base lengths at every point along the segment.



3. Draw a line using your straightedge. Then, use your right angle template and straightedge to construct a line parallel to the first line you drew.



I place my right angle template on  $\overline{WL}$ . I place my straightedge along the edge of the template.



To draw  $\overline{OP}$ , I carefully slide the right angle template down the straightedge.  $\overline{OP}$  is parallel to  $\overline{WL}$ .

## G4-M4-Lesson 5

1. Identify the measures of the following angles.

*The angle measures  $80^\circ$ .*

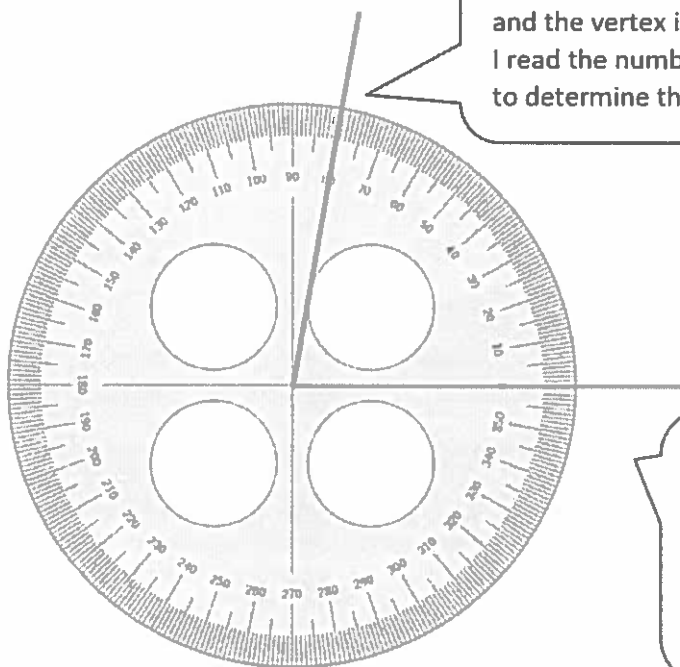

To measure an angle, I place the protractor on the angle so that one of the rays aligns to zero and the vertex is at the center of the protractor. I read the number aligned with the second ray to determine the measure of the angle.

I use a protractor to measure angles. A protractor has tick marks like a ruler, but instead of measuring inches or centimeters, it measures degrees around a point.

2. If you didn't have a protractor, how could you construct one? Use words, pictures, or numbers to explain in the space below.

**Sample Student Response:**

*If I didn't have a protractor, I could cut out a paper circle. Using a right angle template, I could partition the circle in fourths and then mark  $0^\circ$ ,  $90^\circ$ ,  $180^\circ$ ,  $270^\circ$ , and  $360^\circ$ . Although my protractor would not be able to give an exact measurement of any angle, I could estimate the measure using these benchmarks.*

I reflect on my experiences and discussions in class. We partitioned paper circles in various ways, labeling degrees accurately.

## G4-M4-Lesson 6

1. Use a protractor to measure the angle, and then record the measurement in degrees.

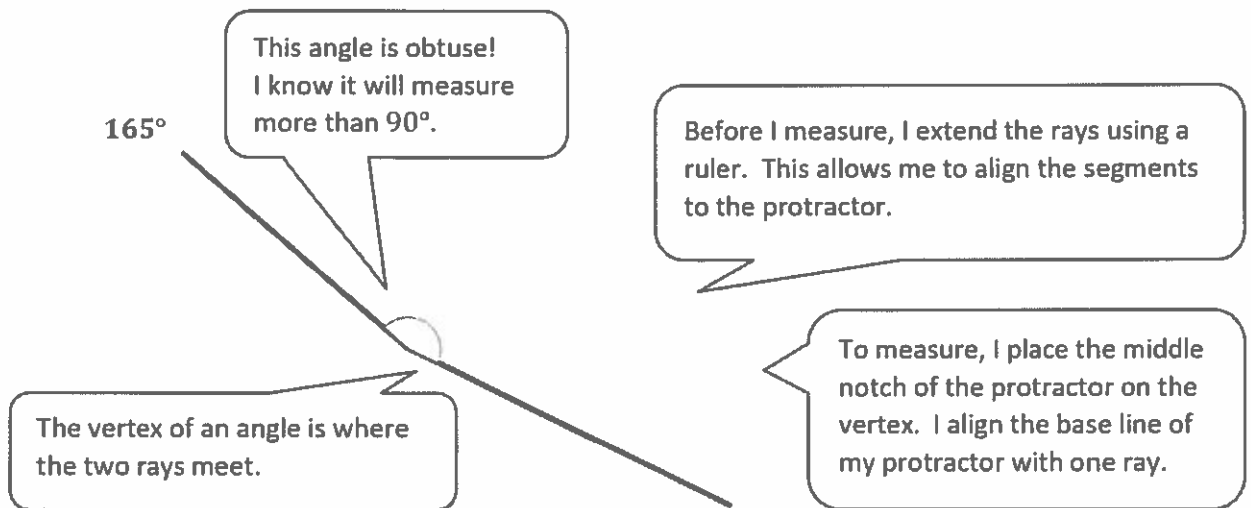

2. Use a protractor to measure the angle. Extend the length of the segments as needed. When you extend the segments, does the angle measure stay the same? Explain how you know.

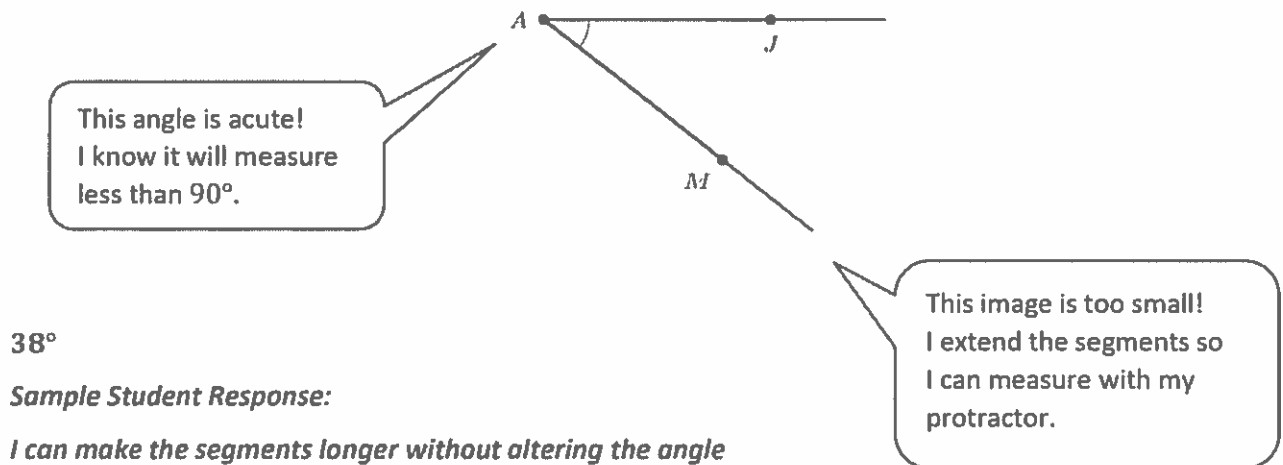

*Sample Student Response:*

*I can make the segments longer without altering the angle measure. I'm not measuring the length of the segments. I'm measuring the degree of the angle. The angle measure stays the same even if the length of the arc changes.*

## G4-M4-Lesson 7

Construct angles that measure the give number of degrees. For the first problem, use the ray shown as one of the rays of the angle with its endpoint as the vertex of the angle. Draw an arc to indicate the angle that was measured.

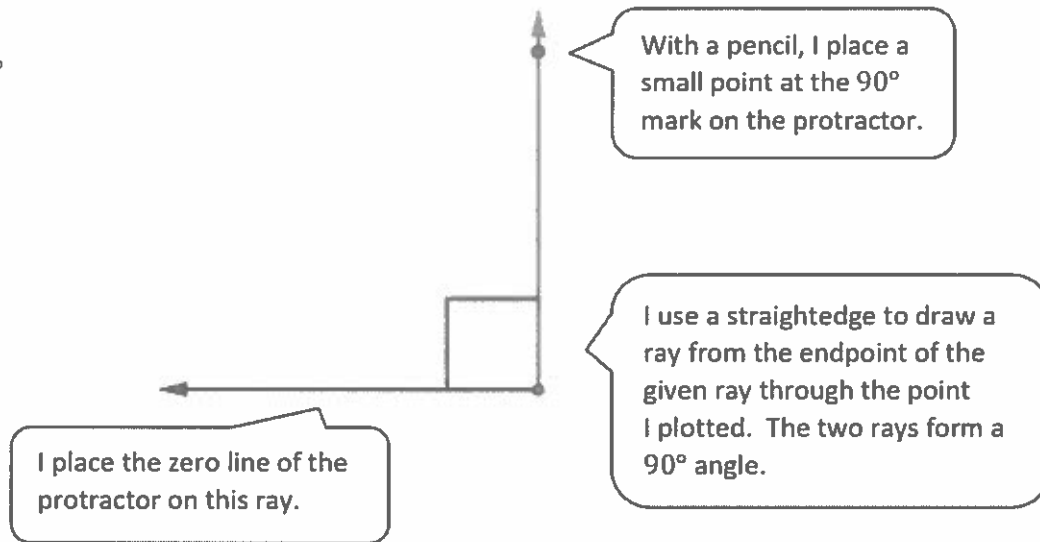
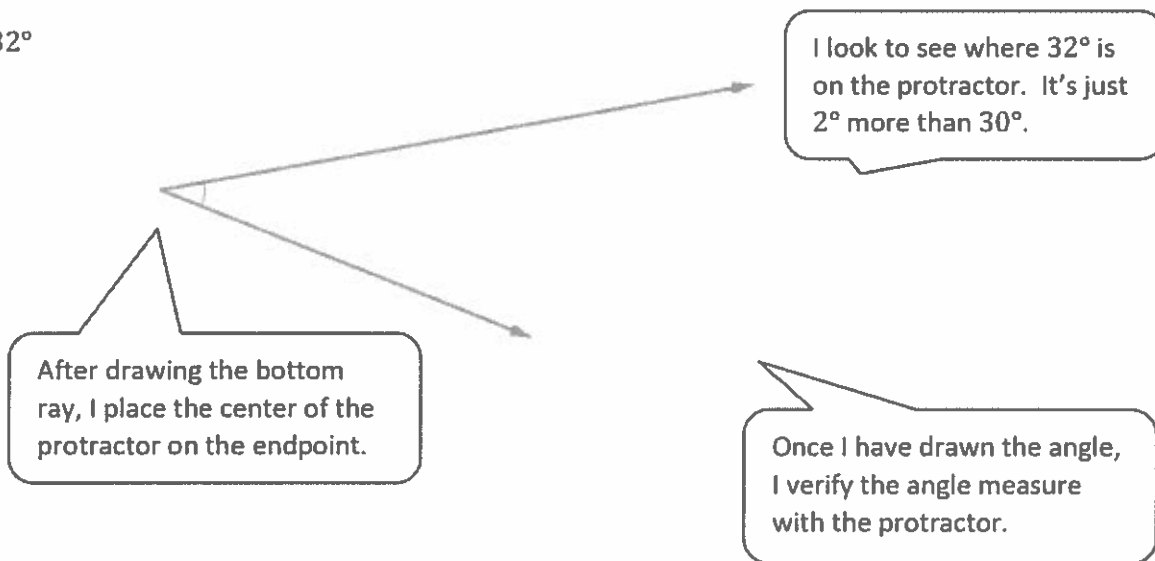
1.  $90^\circ$ 2.  $32^\circ$ 

## G4-M4-Lesson 8

1. James looked at the clock when he put the cake in the oven and when he took it out. How many degrees did the minute hand turn from start to finish?

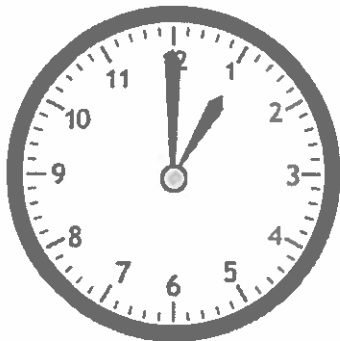

start time

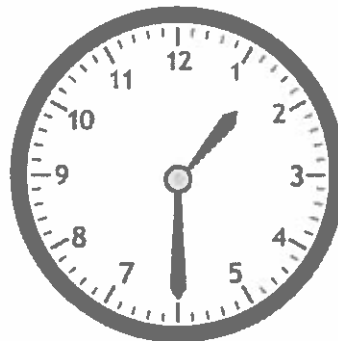

end time

*The minute hand turned  $180^\circ$ .*

I know from Lesson 5 that there are  $360^\circ$  in a full turn. From the 12 to the 3 is a  $90^\circ$  angle, and from the 3 to the 6 is another  $90^\circ$  angle.

2. Delonte turned the lock on his locker one quarter turn to the right and then  $180^\circ$  to the left. Draw a picture showing the position of the lock after he turned it.

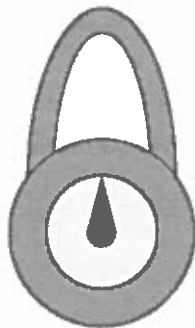

before

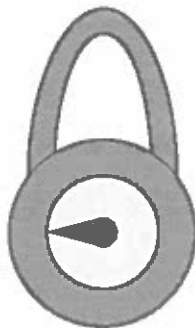

after

I think of the lock as a clock. A quarter-turn to the right is 15 minutes, and  $180^\circ$  to the left is 30 minutes backward.

3. How many quarter-turns does the picture need to be rotated in order for it to be upright?

*To be upright, the picture needs to be turned two quarter-turns.*

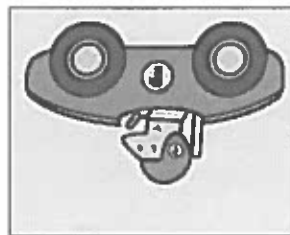

I can turn the paper itself to help me figure out the answer!

G4-M4-Lesson 9

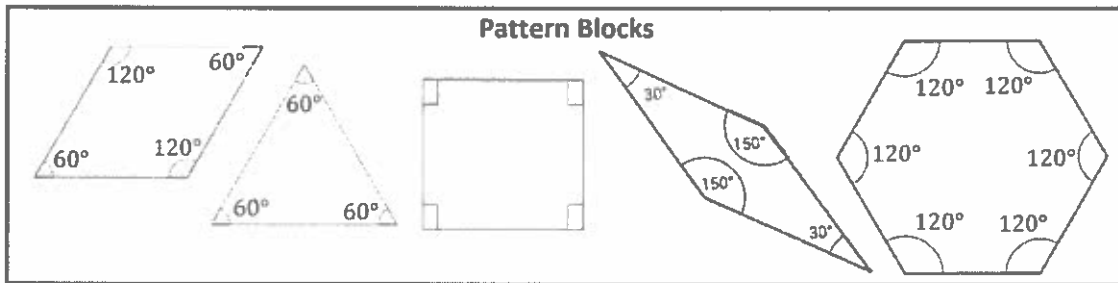

1. Sketch one way to compose  $\angle ABC$  using two or more pattern blocks. Write an addition sentence to show how you composed the given angle.

$\angle ABC = 150^\circ$

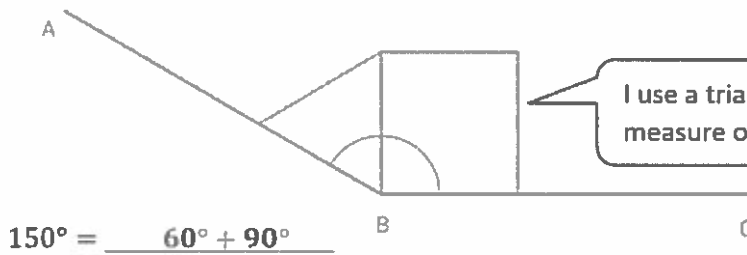

I use a triangle and a square. I add the measure of each angle:  $60^\circ + 90^\circ = 150^\circ$ .

2. Sabrina built the following shape with her pattern blocks. As indicated by their arcs, solve for  $x^\circ$ ,  $y^\circ$ , and  $z^\circ$ . Write an addition sentence for each. The first one is done for you.

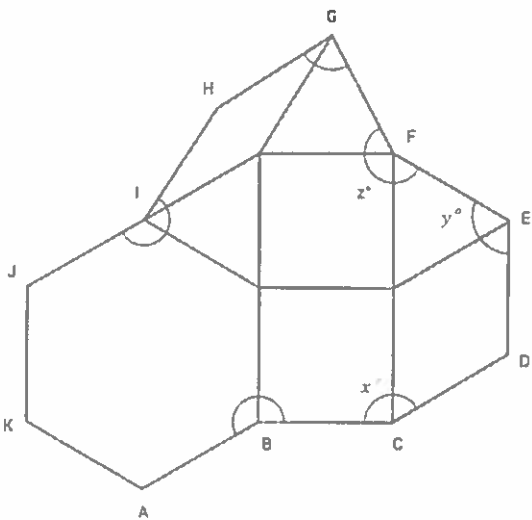

- a.  $y^\circ = 60^\circ + 60^\circ$   
 $y^\circ = 120^\circ$
- b.  $z^\circ = \underline{60^\circ + 90^\circ + 60^\circ}$   
 $z^\circ = \underline{210^\circ}$
- c.  $x^\circ = \underline{90^\circ + 60^\circ}$   
 $x^\circ = \underline{150^\circ}$

To determine  $x^\circ$ ,  $y^\circ$ , and  $z^\circ$ , I add together the smaller angles encompassed by the arcs. I use the chart at the top of the page to determine the measure of each of the smaller angles.

### G4-M4-Lesson 10

1. Write an equation, and solve for the measurement of  $\angle x$ . Verify the measurement using a protractor.

a.  $\angle JKL$  is a straight angle.

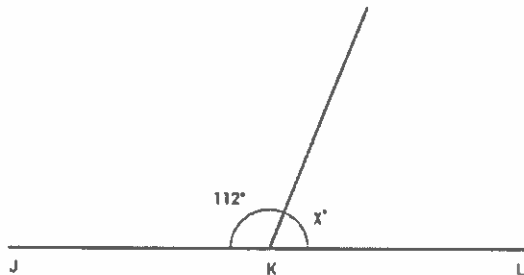

$$\underline{112^\circ} + \underline{68^\circ} = \underline{180^\circ}$$

$$x^\circ = \underline{68^\circ}$$

$$\begin{array}{r} 7 \ 10 \\ 1 \ 8 \ 0 \\ - 1 \ 3 \ 2 \\ \hline 0 \ 4 \ 8 \end{array}$$

I know a straight angle measures  $180^\circ$ . I subtract  $112^\circ$  from  $180^\circ$  to find the value of  $x^\circ$ . To verify my answer, I use my protractor to measure the angle. It measures  $68^\circ$ .

b. Solve for the measurement of  $\angle USW$ .  $\angle RST$  is a straight angle.

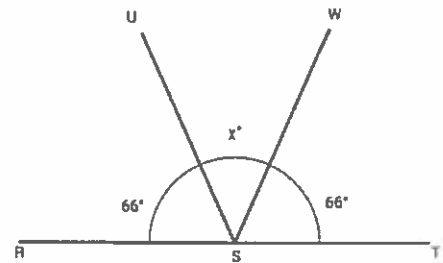

$$66^\circ + 66^\circ + x^\circ = 180^\circ$$

$$132^\circ + x^\circ = 180^\circ$$

$$x^\circ = 48^\circ$$

$$\angle USW = 48^\circ$$

I know that the sum of these three angle measures is  $180^\circ$ . I add the two parts that I know and then I subtract their total from  $180^\circ$ .

2. Complete the following directions in the space to the right.

- Draw 2 points:  $S$  and  $T$ . Using a straightedge, draw  $\overleftrightarrow{ST}$ .
- Plot a point  $U$  somewhere between points  $S$  and  $T$ .
- Plot a point  $W$ , which is not on  $\overleftrightarrow{ST}$ .
- Draw  $\overline{UW}$ .
- Find the measure of  $\angle SUW$  and  $\angle TUW$ .
- Write an equation to show that the angles add to the measure of a straight angle.

Sample Response:

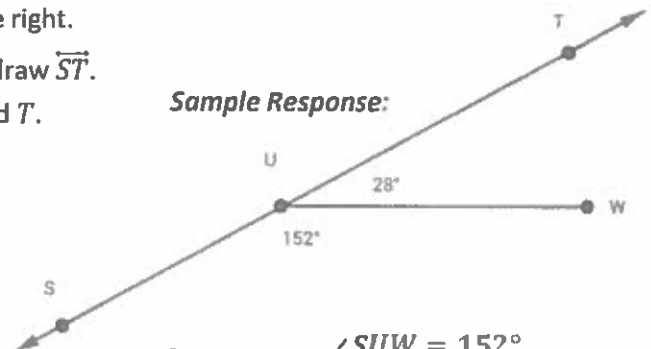

$$\angle SUW = 152^\circ$$

$$\angle TUW = 28^\circ$$

$$152^\circ + 28^\circ = 180^\circ$$

I draw the figure. I use my protractor to measure  $\angle SUW$  and  $\angle TUW$ .

G4-M4-Lesson 11

Write an equation, and solve for the unknown angle measurements numerically.

1.

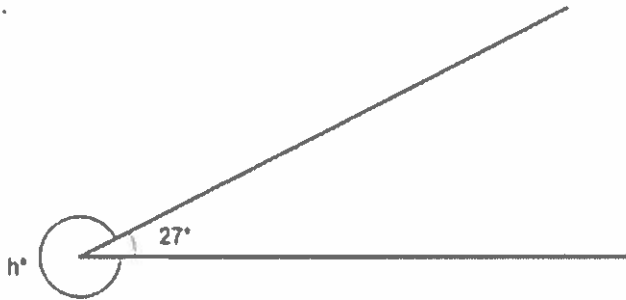

I know from Lesson 5 that a circle measures  $360^\circ$ .  
I solve for  $h^\circ$  by subtracting  $27^\circ$  from  $360^\circ$ .

$$\underline{27^\circ} + \underline{333^\circ} = 360^\circ$$

$$h^\circ = \underline{333^\circ}$$

		5	10
	3	<del>6</del>	<del>0</del>
-		2	7
<hr/>			
	3	3	3

2.

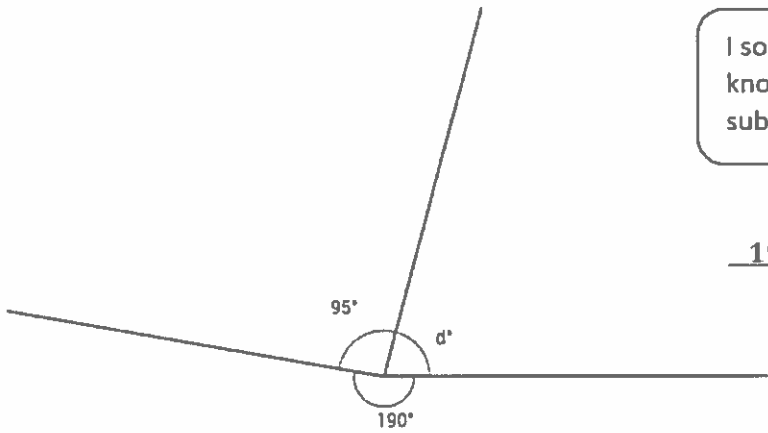

I solve for  $d^\circ$  by adding together the known angle measures and then subtracting their sum from  $360^\circ$ .

$$\underline{190^\circ} + \underline{95^\circ} + \underline{75^\circ} = \underline{360^\circ}$$

$$d^\circ = \underline{75^\circ}$$

	1	9	0
+		9	5
<hr/>			
	2	8	5

		15	
	2	<del>8</del>	10
-		<del>3</del>	<del>0</del>
	2	8	5
<hr/>			
	7	5	



3.  $T$  is the intersection of  $\overline{UV}$  and  $\overline{WX}$ .  
 $\angle UTW$  is  $51^\circ$ .

$$g^\circ = \underline{129^\circ} \quad h^\circ = \underline{51^\circ} \quad i^\circ = \underline{129^\circ}$$

$$\begin{aligned} 129^\circ + h^\circ &= 180^\circ \\ h^\circ &= 51^\circ \end{aligned}$$

$$\begin{aligned} 51^\circ + i^\circ &= 180^\circ \\ i^\circ &= 129^\circ \end{aligned}$$

I can solve for  $i^\circ$  by thinking of its relationship to either  $\overline{UV}$  or  $\overline{WX}$ . But I also notice that opposite angles measure the same for this figure.

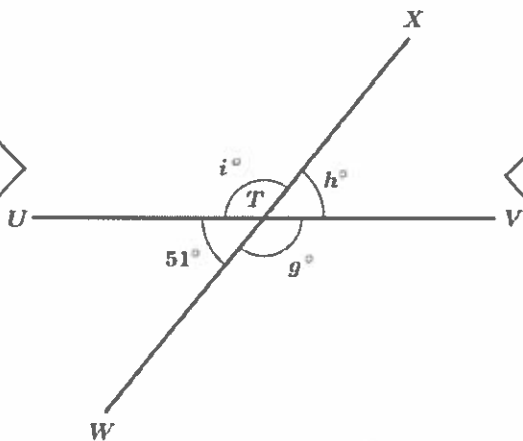

I solve for  $h^\circ$  by thinking about the relationships of  $\angle WTV$  and  $\angle VTX$ . Both angle measures add to  $180^\circ$  because they are on  $\overline{WX}$ .

I solve for  $g^\circ$  by thinking of its relationship to  $\angle UTV$ .  $\angle UTV$  is a straight angle that measures  $180^\circ$ .

$$\begin{aligned} 51^\circ + g^\circ &= 180^\circ \\ g^\circ &= 129^\circ \end{aligned}$$

$$\begin{array}{r} \phantom{1} \phantom{0} \phantom{0} \\ \phantom{1} \phantom{0} \phantom{0} \\ - \phantom{1} \phantom{0} \phantom{0} \\ \hline 1 \phantom{0} \phantom{0} \phantom{0} \end{array}$$

4.  $P$  is the intersection of  $\overline{QR}$ ,  $\overline{ST}$ , and  $\overline{UP}$ .  
 $\angle QPS$  is  $56^\circ$ .

$j^\circ = \underline{124^\circ}$      $k^\circ = \underline{56^\circ}$      $m^\circ = \underline{34^\circ}$

$$\begin{array}{r} 7 \ 10 \\ 1 \ 8 \ 0 \\ - \ 5 \ 6 \\ \hline 1 \ 2 \ 4 \end{array}$$

$$\begin{aligned} 56^\circ + j^\circ &= 180^\circ \\ j^\circ &= 124^\circ \end{aligned}$$

$$\begin{aligned} 124^\circ + k^\circ &= 180^\circ \\ k^\circ &= 56^\circ \end{aligned}$$

$$\begin{array}{r} 7 \ 10 \\ 1 \ 8 \ 0 \\ - \ 1 \ 2 \ 4 \\ \hline 0 \ 5 \ 6 \end{array}$$

I solve for  $j^\circ$  by thinking of the relationship  $\angle SPQ$  and  $\angle QPT$  have to  $\overline{ST}$ .

I solve for  $k^\circ$  by thinking of the relationship  $\angle QPT$  and  $\angle TPR$  have to  $\overline{QR}$ .

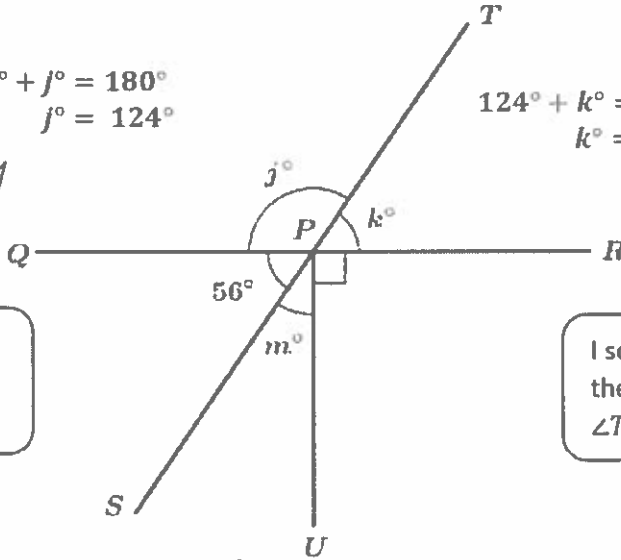

I solve for  $m^\circ$  by noticing that  $\angle UPR$  is a right angle; therefore,  $\angle UPQ$  is also a right angle.

$$\begin{aligned} 56^\circ + m^\circ &= 90^\circ \\ m^\circ &= 34^\circ \end{aligned}$$

$$\begin{array}{r} 8 \ 10 \\ 9 \ 0 \\ - \ 5 \ 6 \\ \hline 3 \ 4 \end{array}$$

G4-M4-Lesson 12

I can tell parts (b) and (d) each have a line of symmetry because the figure in each part is the same on both sides of the line.

1. Circle the figures that have a correct line of symmetry drawn.

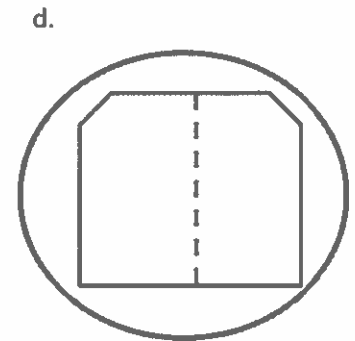
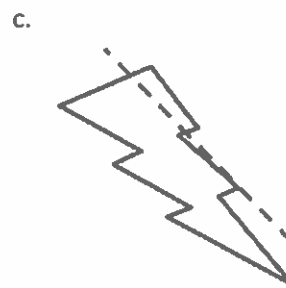
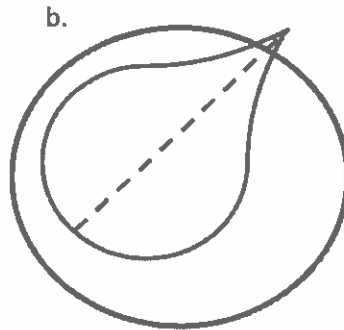
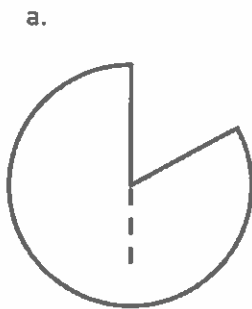

2. Find and draw all lines of symmetry for the following figures. Write the number of lines of symmetry that you found in the blank underneath the shape.

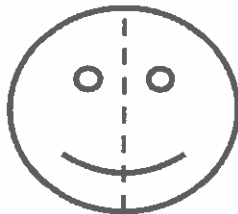

a.   1  

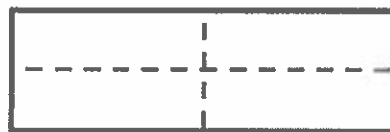

b.   2  

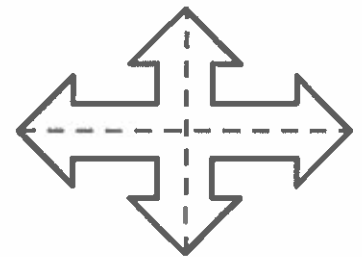

c.   2  

I think about folding these shapes in half many different ways. If the shapes match where I fold them, that is a line of symmetry.

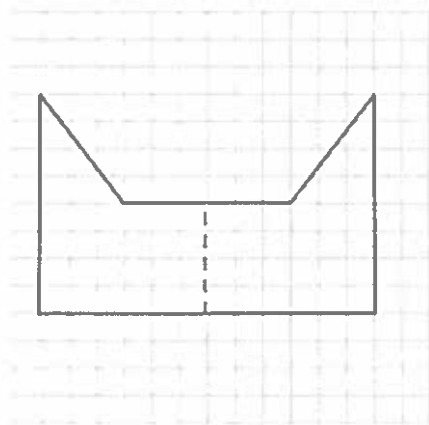

3. Half of the figure below has been drawn. Use the line of symmetry, represented by the dashed line, to complete the figure.



I use the grid to help me complete the figure. I count how many units long each segment is, and then I draw segments of the same length for the other half of the figure. I draw the sides that follow the grid lines first, and then I make the diagonal line.

## G4-M4-Lesson 13

1. Classify each triangle by its side lengths and angle measurements. Circle the correct names.

	Classify Using Side Lengths	Classify Using Angle Measurements
a. 	Equilateral   Isosceles <b>Scalene</b>	Acute <b>Right</b> Obtuse
b. 	Equilateral <b>Isosceles</b> Scalene	Acute   Right <b>Obtuse</b>
c. 	<b>Equilateral</b> Isosceles   Scalene	<b>Acute</b> Right   Obtuse

Sometimes triangles are drawn with tick marks, little dashes perpendicular to the sides of the triangle. These tick marks mean that those sides have the same length.

To classify by side lengths, I use a ruler to measure each side of the triangle or look to see if tick marks are drawn. Equilateral triangles have sides that are all the same length. Isosceles triangles have two sides that are the same length. Scalene triangles have sides that are all different lengths.

To classify by angle measure, I can use a protractor or a right angle template. An acute triangle has three angles less than  $90^\circ$ . A right triangle has one  $90^\circ$  angle. An obtuse triangle has one angle greater than  $90^\circ$ .

2. Use a ruler to connect points to form two other triangles. Use each point only once. None of the triangles may overlap. One point will be unused. Name and classify the three triangles below. The first one has been done for you.

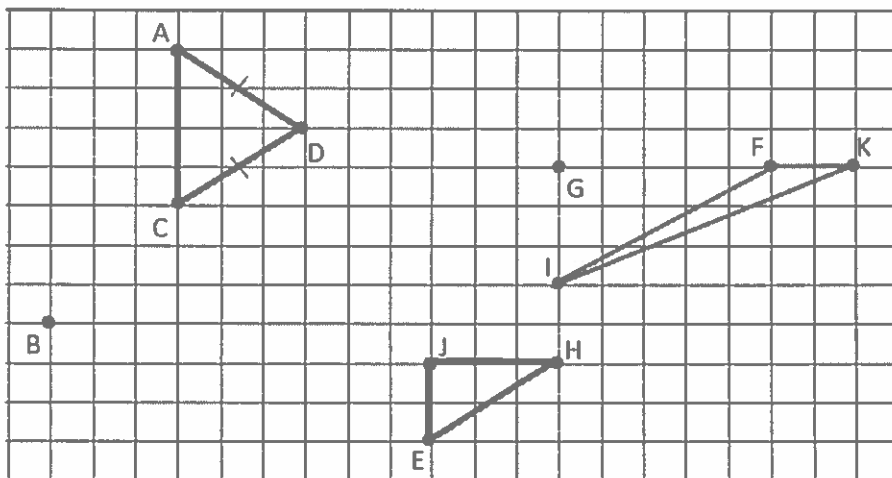

I draw two triangles and then classify each of them. I look back to the first problem to recall how to classify the triangles.

Name the Triangles Using Vertices	Classify by Side Length	Classify by Angle Measurement
$\triangle FKI$	Scalene	Obtuse
$\triangle ACD$	Isosceles	Acute
$\triangle EHJ$	Scalene	Right

3. Can a triangle have two obtuse angles? Explain.

Sample answer:

No, if a triangle had two obtuse angles, the three sides could never meet.

I draw two obtuse angles, and I see that the three sides can't form a triangle since two of the line segments will continue to get farther apart instead of closer together if I make them longer.



## G4-M4-Lesson 14

1. Draw triangles that fit the following classifications. Use a ruler and protractor. Label the side lengths and angles.

a. Acute and equilateral

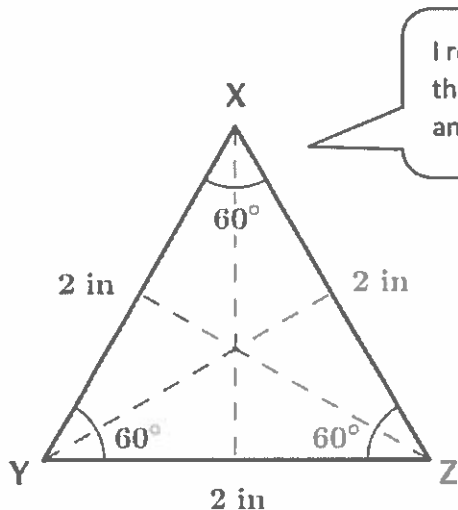

I remember from Lesson 9 that an equilateral triangle has angle measurements of  $60^\circ$ .

To draw this triangle, I first use my protractor to draw the right angle. Then I use my ruler to make sure  $\overline{EG}$  and  $\overline{GF}$  are the same length.

b. Right and isosceles

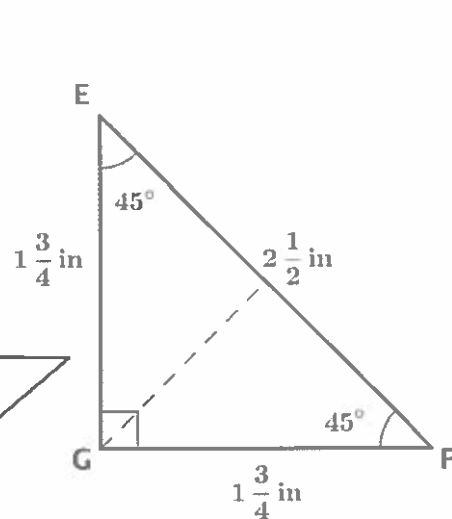

2. Draw all possible lines of symmetry in the triangles above.

$\triangle XYZ$  has three lines of symmetry because it is an equilateral triangle.  
 $\triangle EFG$  has one line of symmetry because it is an isosceles triangle.

3.  $\triangle EFG$  can be described as a right triangle and a scalene triangle. True or False?

*Sample answer:*

*False.  $\triangle EFG$  is isosceles and right. I know this because two of the sides are the same length, and there is a right angle.*

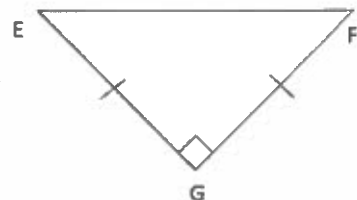

4. If  $\triangle ABC$  is an equilateral triangle,  $\overline{BC}$  must be 1 cm. True or False?

**Sample answer:**

**True.** If  $\triangle ABC$  is equilateral, that means that all of the side lengths must be the same length. So, if two of the sides are 1 cm, the third side must also be 1 cm.

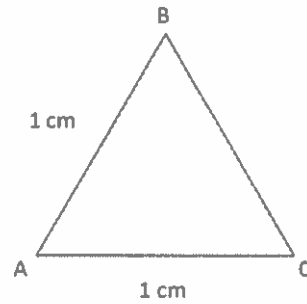



## G4-M4-Lesson 15

I use what I learned in Lessons 3 and 4 to draw parallel and perpendicular lines using a right angle template and a ruler.

Construct the following figures based on the given attributes. Give a name to each figure you construct. Be as specific as possible.

1. A quadrilateral with opposite sides the same length and four right angles

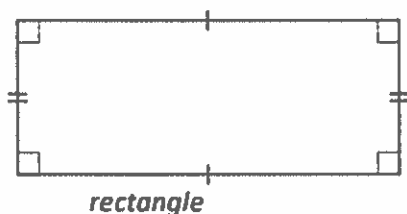

I draw the bottom segment using my ruler. I draw the two sides using my right angle template and ruler to make right angles and to make the left and right side lengths equal. I draw the top segment perpendicular to the sides and parallel to the bottom segment. I draw small squares to show the right angles and tick marks to show which sides are equal.

2. A quadrilateral with one set of parallel sides

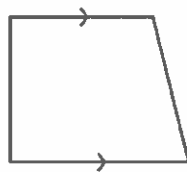

I draw a horizontal segment. I draw a segment that is parallel to the first segment. I connect the endpoints of the segments. I draw arrows to label the parallel sides.

3. A quadrilateral with two sets of parallel sides

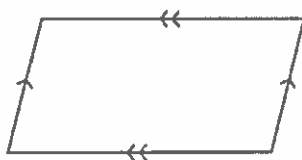

I start by drawing horizontal, parallel sides just as when I started drawing a trapezoid. After I draw the left side segment, I make sure the right side segment is parallel to it. I add arrows on the opposite segments to show they are parallel to each other.

4. A parallelogram with all sides the same length and four right angles

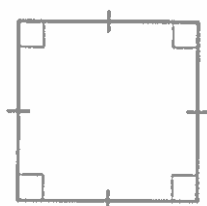

square

I start by drawing a parallelogram, except I draw the left side segment perpendicular to the horizontal segments. I measure the left side segment and make sure to make the top and bottom segments the same lengths. I draw a right segment perpendicular to the top and bottom segments. It will be the same length as all other sides. I add tick marks and right angle squares.

## G4-M4-Lesson 16

1. Construct a quadrilateral with all sides of equal length. What shape did you create?

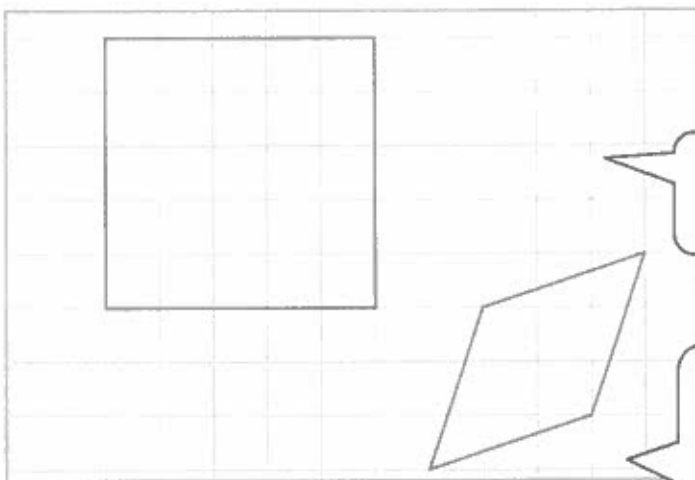

*Sample Response:*

*I created a square.*

I trace the gridlines to draw line segments of equal length, constructing a square.

*I created a rhombus.*

I look for a pattern on the grid to draw a rhombus. I draw segments that go diagonally across three squares of the grid.

2. Construct a quadrilateral with two sets of parallel sides. What shape did you create?

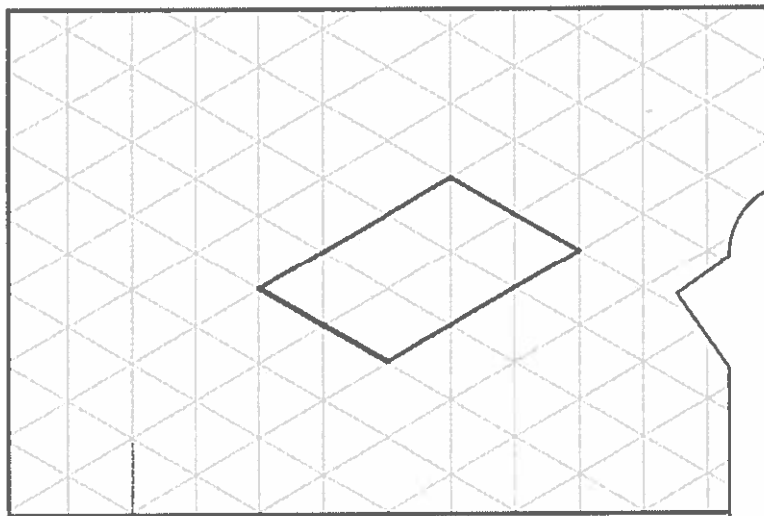

*Sample Response:*

*I created a parallelogram.*

I trace along one of the diagonal gridlines. I draw a second segment parallel to the first by tracing along a gridline two triangle side lengths away. I draw the third and fourth segments by tracing along two other diagonal gridlines going in the opposite direction. I use a ruler and right angle template to verify that the sets of sides are parallel.

I also could have drawn a rectangle, a square, or a rhombus because they are also quadrilaterals with two sets of parallel sides.

