

**Tangrams** are ancient Chinese puzzles that are still used today by adults as well as children. The story of the tangram is over 4000 years old. It is said that a poor, Chinese scholar named Tan was on his way to deliver a square ceramic tile to his emperor. On the way it dropped and broke into seven pieces. While trying to reassemble the square, the scholar discovered other fascinating shapes and patterns.

A tangram begins with a **square**, which is then cut into **seven** standard pieces. Each piece is called a **tan**. In creating a picture, all seven tans must be used; they must touch but none may overlap.

When tangrams are used in storytelling, the storyteller arranges the tans to show the shape of a character in the tale. As new characters or story elements are introduced, the puzzle pieces are rearranged to represent the new character or new element.

The fox fairies in **Grandfather Tang's Story**, by **Ann Tompert**, are an integral part of Chinese folklore. They are believed to be endowed with supernatural powers of transformation. Fox fairies are said to live for eight hundred to a thousand years.

# THE TANGRAM ZOO

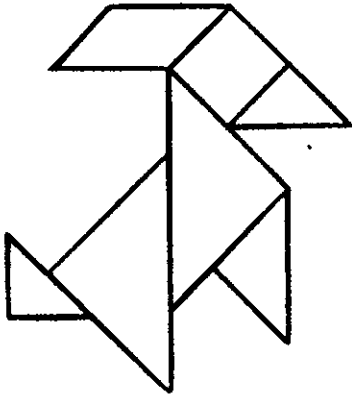

35

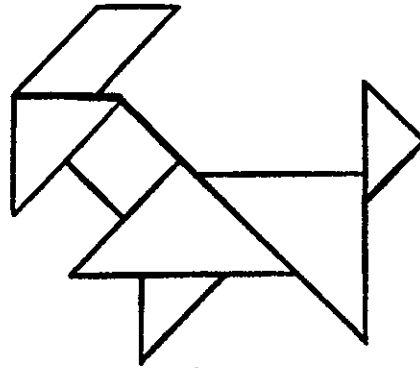

36

GOATS

*Polar Bear*

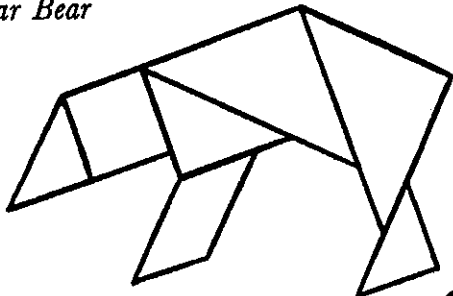

37

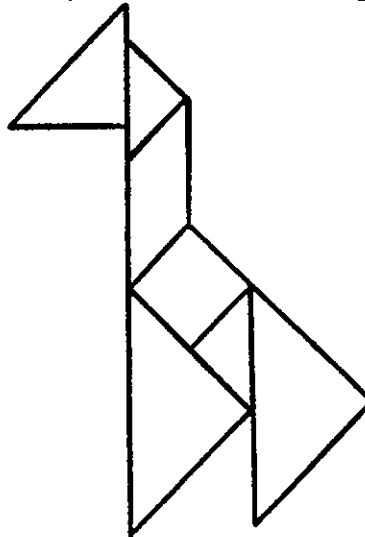

38 Giraffe

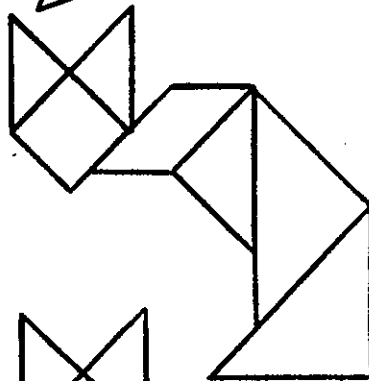

40

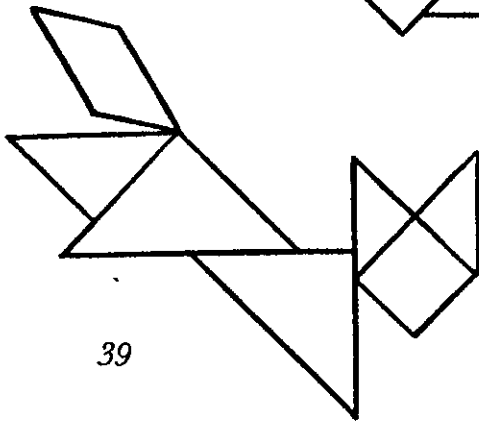

39

CATS

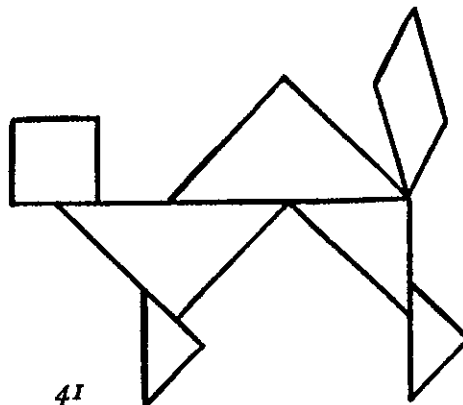

41

CATS AND DOGS

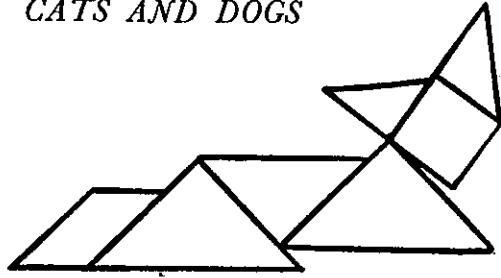

42

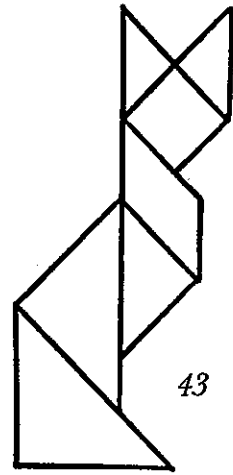

43

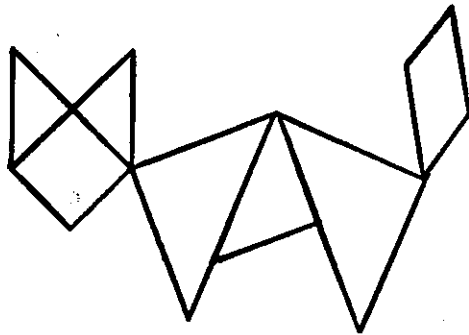

44

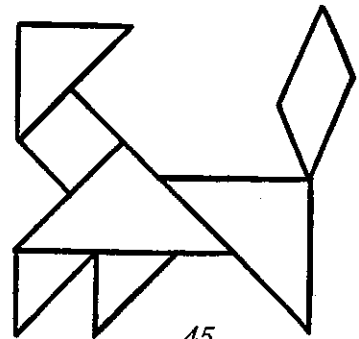

45

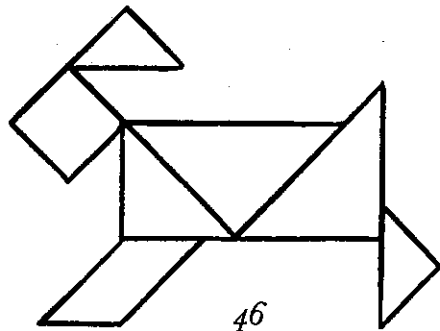

46

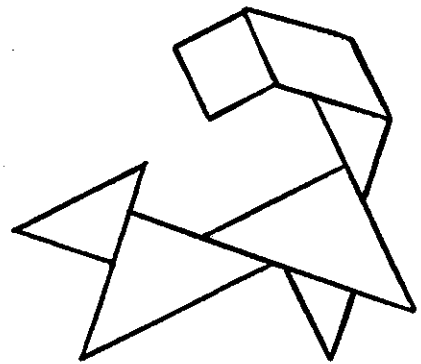

48 Squirrel

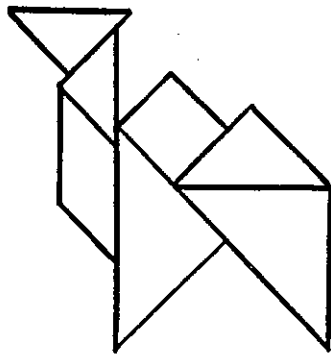

47 Camel

BIRDS

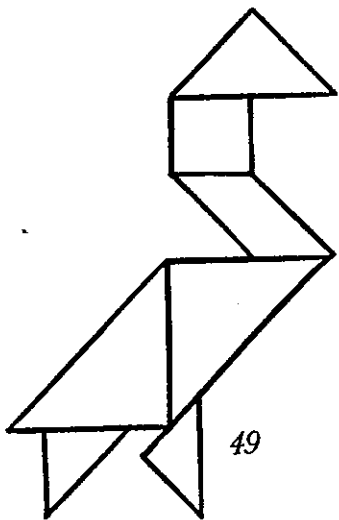

49

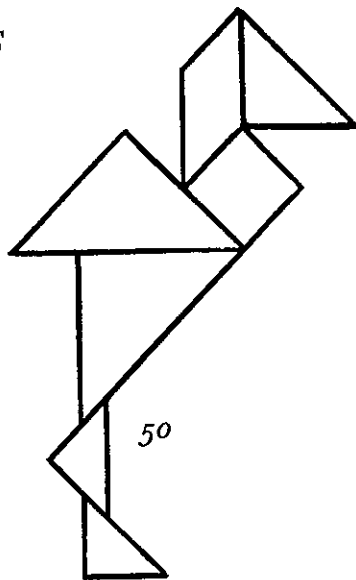

50

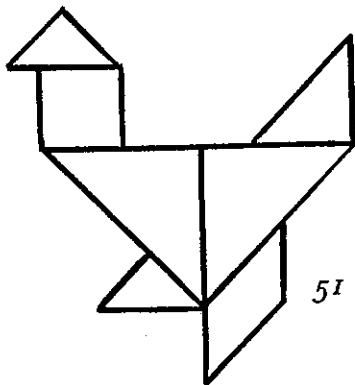

51

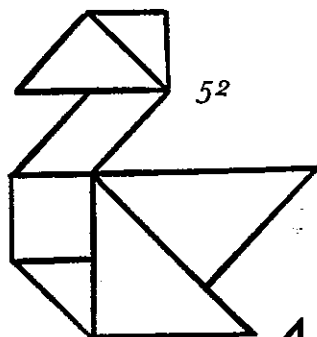

52

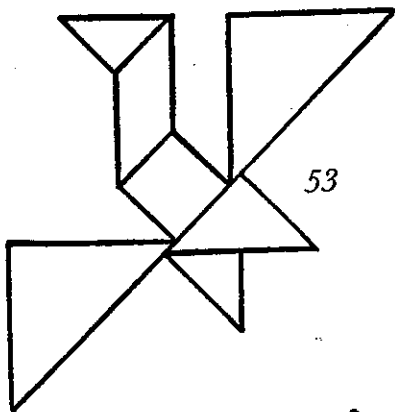

53

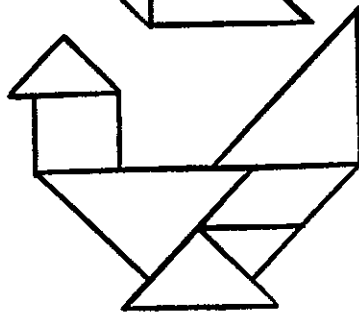

54

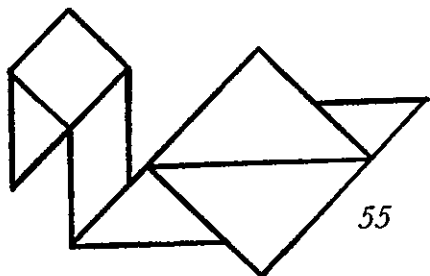

55

MORE BIRDS

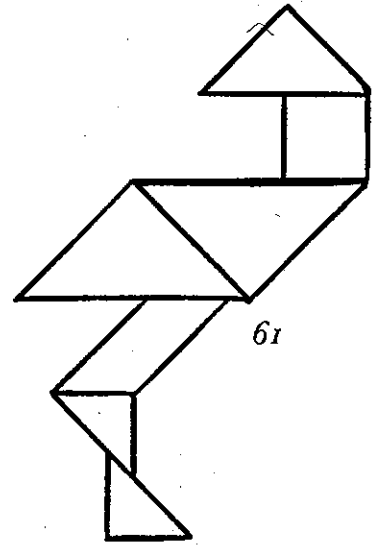
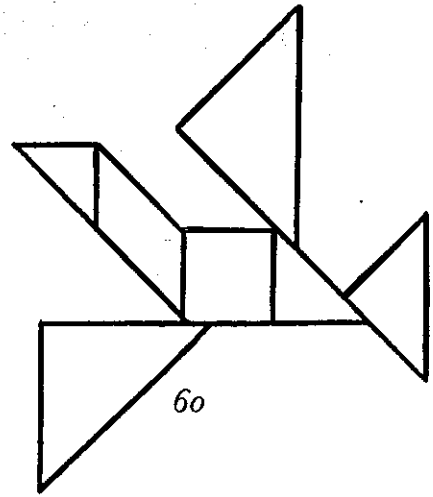
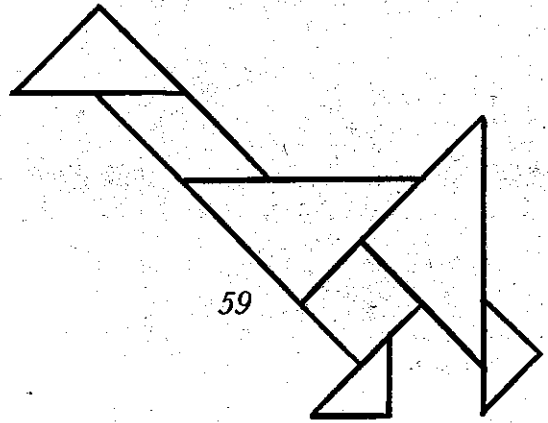
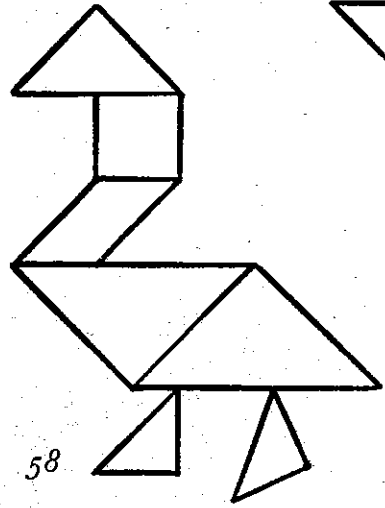
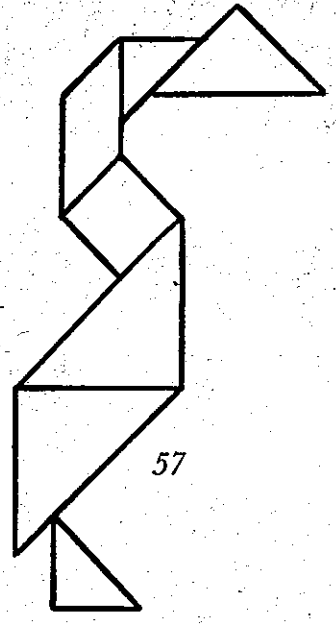
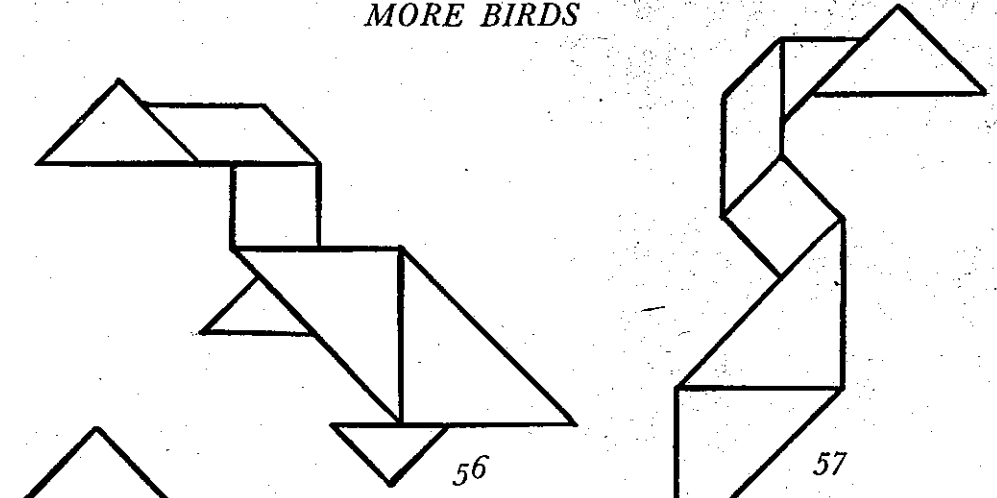

SEA CREATURES

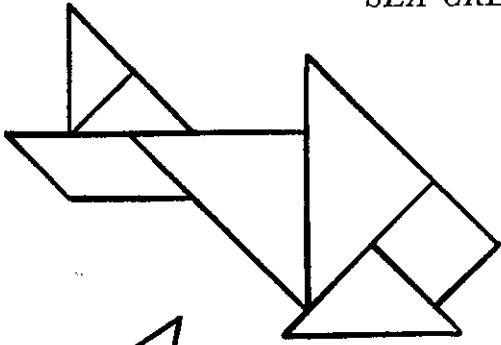

76

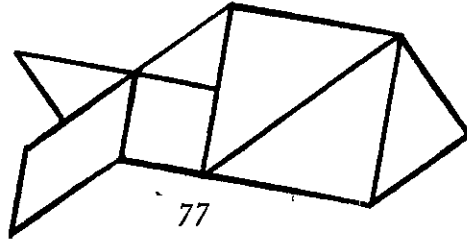

77

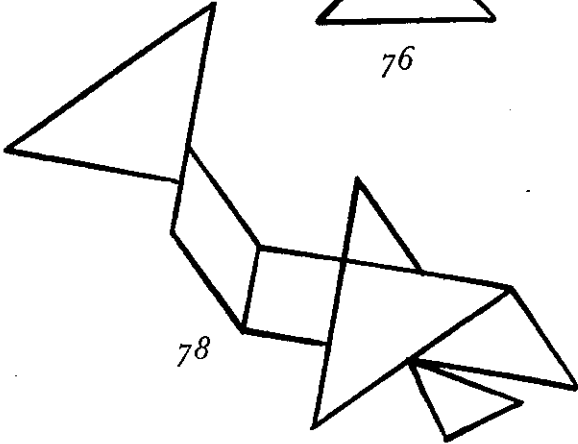

78

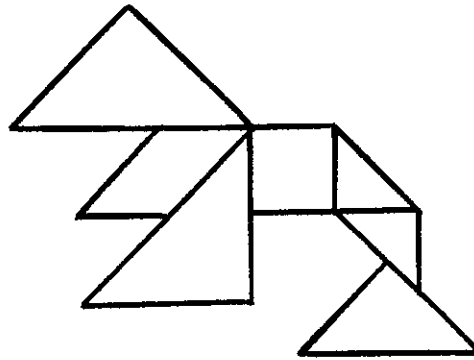

79 Lobster

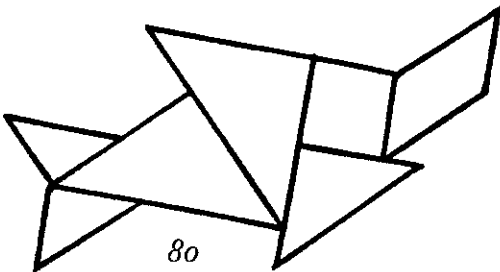

80

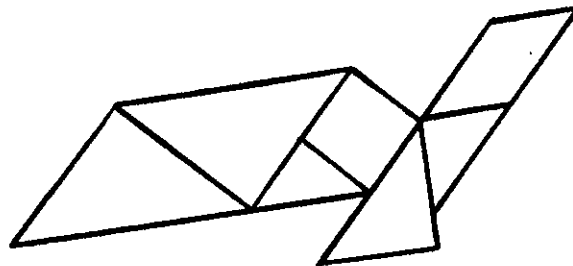

81 Turtle

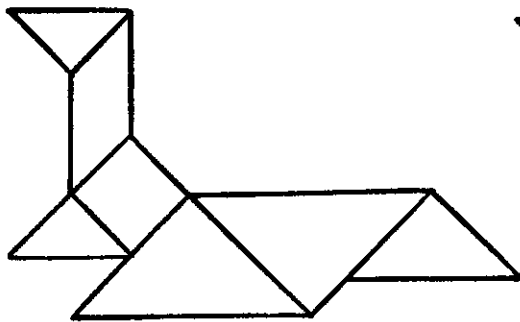

82 Seal

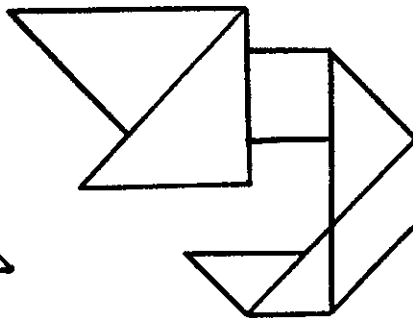

83 Shrimp